



JOURNAL ON COMMUNICATIONS

ISSN:1000-436X

REGISTERED

Scopus®

www.jocs.review

A Review of Critical Enhancements in Wind Energy Converter for Consistent Performance

Deep Mala¹, E Vijay Kumar²

^{1,2} Department of Electrical Engineering

^{1,2} SRK University, Bhopal

Abstract

The demand for power has increased the necessity for renewable energy sources and the challenge of generating clean, green electricity. Relying solely on solar energy during daytime has prompted individuals to seek improved and more consistent prospects in the wind sector. This research investigated the potential expansion of the Indian wind sector and formulated a research hypothesis that offers a comprehensive evaluation of the challenges and issues linked to grid integration for wind turbines. This research explored the evolution of converters in wind turbines and the issues that have arisen in them over the past years. It also explored the need for reactive power in WEC and the role of the FACT device. The final section reviews and analyzes the techniques for monitoring the Maximum Power from WEC. The function of algorithms is examined as they proved useful for monitoring Maximum Power while enhancing power quality and stability

Introduction

The Renewable Energy Country Attractive Index ranks India third for renewable energy potential in 2021 [1]. It consumes the third-most energy worldwide. By 2030, the nation wants 500 GW of renewable energy capacity. By 2022, 175 GW. India had the fourth-largest wind power capacity (40.893 GW) on July 31, 2022 [2]. Tamil Nadu's 1500 MW Muppandal wind farm was India's largest. Suzlon Energy's 1,600 MW Jaisalmer wind farm is India's largest [3]. The government offers expedited depreciation and custom duty exemption on wind electric generator components to promote wind power nationwide. Chennai's National Institute of Wind Energy locates and assesses wind resources. Wind projects commissioned before March 31, 2017, were eligible for the Generation Based Incentive (GBI). The government removed interstate transmission costs and losses for wind and solar projects commissioned by March 2022 to promote wind power sales across India [4]. This step is expected to encourage private sector investment in wind power projects and facilitate the growth of the wind power industry

in India. Figure 1 indicates the existing potential of wind energy converters state-wise, while Fig. 2 shows year-wise growth of wind power installation in India it can be clearly observed here that after 2017 the installations were reduced as there was a strategic impact of COVID-19 on industries, again the industries have increased their potential size and in Fig. 3 it can be clearly understood the forecast of the Indian government to increase renewable energy penetration. But behind the scenes, there are challenges to accepting wind energy converters as in order to integrating WEC with the grid at the same frequency and voltage stability limits is difficult [5]. In the later part, challenges are covered for a wind energy converter for its synchronization to grid.

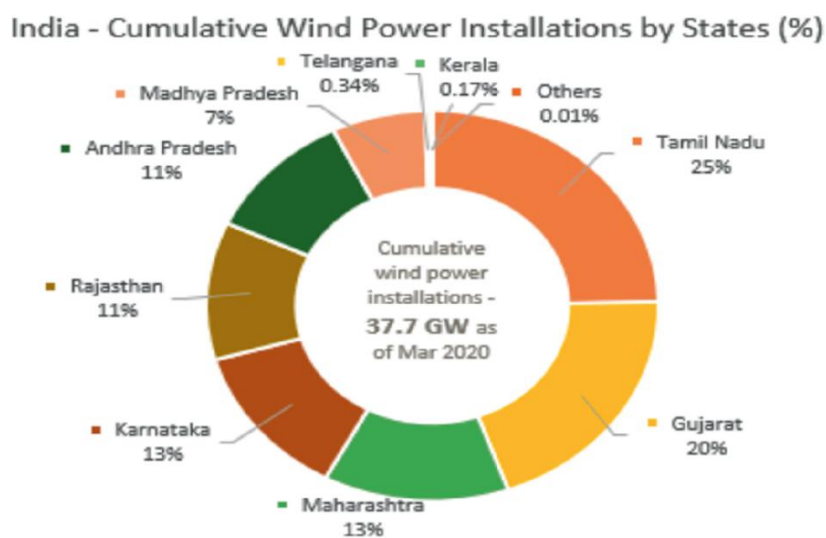

Figure 1: State-Wise Wind Power Convertors Installation [2]

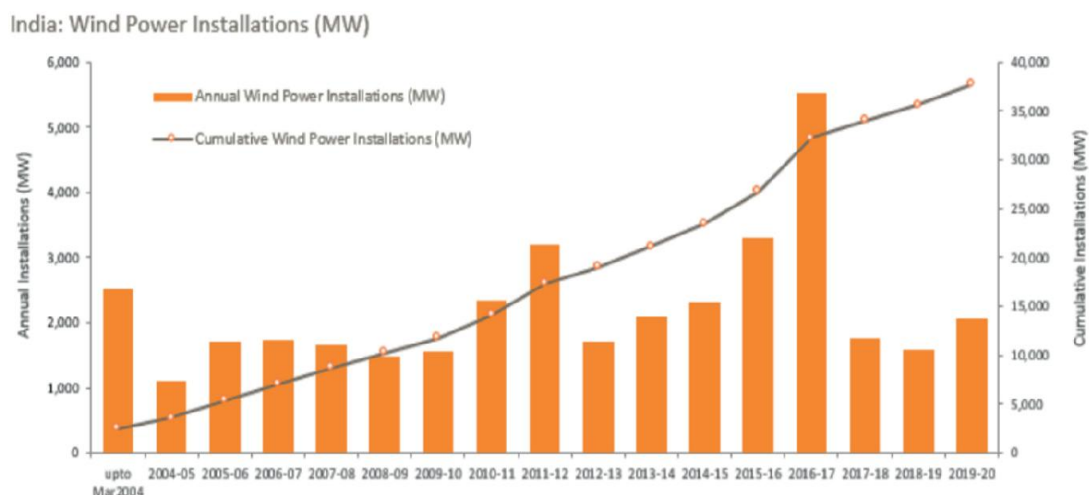

Figure 2: Year-Wise Growth of Wind Power Installation in India [5]

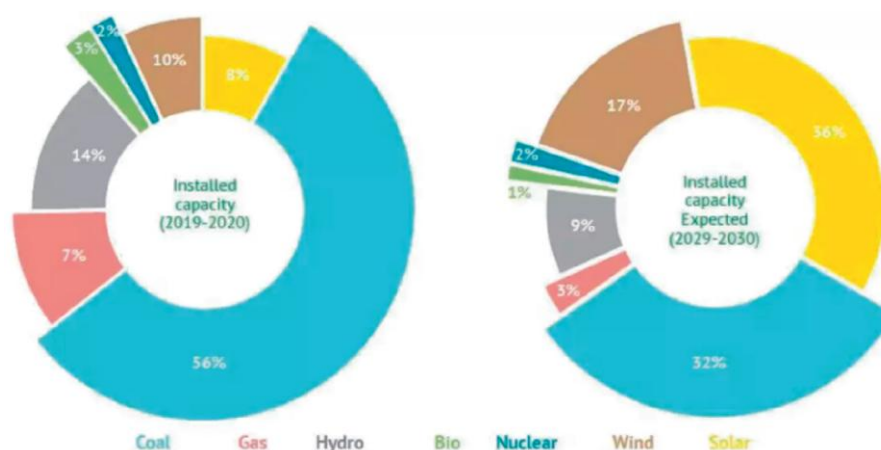

Figure 3: Projected Increase in Wind Energy Potential by 2030

The 2021 Renewable Energy Country Attractive Index placed India third for renewable energy potential [1]. It consumes the third-most energy globally. By 2030, the country wants 500 GW of renewable energy capacity. By 2022, 175 GW. On July 31, 2022, India had the fourth-largest wind power capacity (40.893 GW) [2]. Tamil Nadu's 1500-MW Muppandal wind farm was India's largest. Suzlon Energy's 1,600MW Jaisalmer wind farm is India's largest [3]. The government accelerates depreciation and reduces custom duties on wind electric generator components to promote wind power. The Chennai-based National Institute of Wind Energy assesses wind resources and sites. The Generation Based Incentive (GBI) was available for wind projects started before March 31, 2017. Wind and solar projects completed by March 2022 have no government interstate transmission fees or losses [4].

Outline of the Paper

Given the challenges, this paper reviews the key papers that have improved WEC grid stability. After understanding the challenges, it was clear that power electronics converters would be essential to WEC stability. Sections of relevant study papers were reviewed. After discussing the understanding and necessity of wind turbine convertor evolution examines power system faults that may arise with the integration of wind energy converters and how to diagnose them. After reading more papers, reactive power management is needed for variable wind speed generation and continuous load shift. In MPPT in Wind Farms and WEC Stability algorithms were examined. Finally, developed sources must be assessed and extracted for optimum power. Figure 4 graphs the number of articles reviewed and classified. This review paper has divided

the material into parts and drafted each section's essential details one at a time. Figure 7 shows the review paper study methodology-labelled parts (Fig. 5).

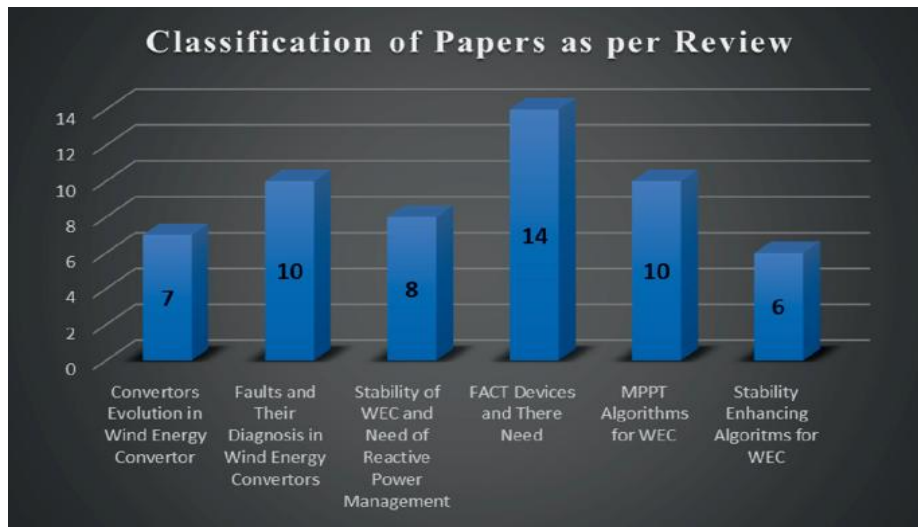

Figure 4: Number of Papers Reviewed for the Research Work and their Classification

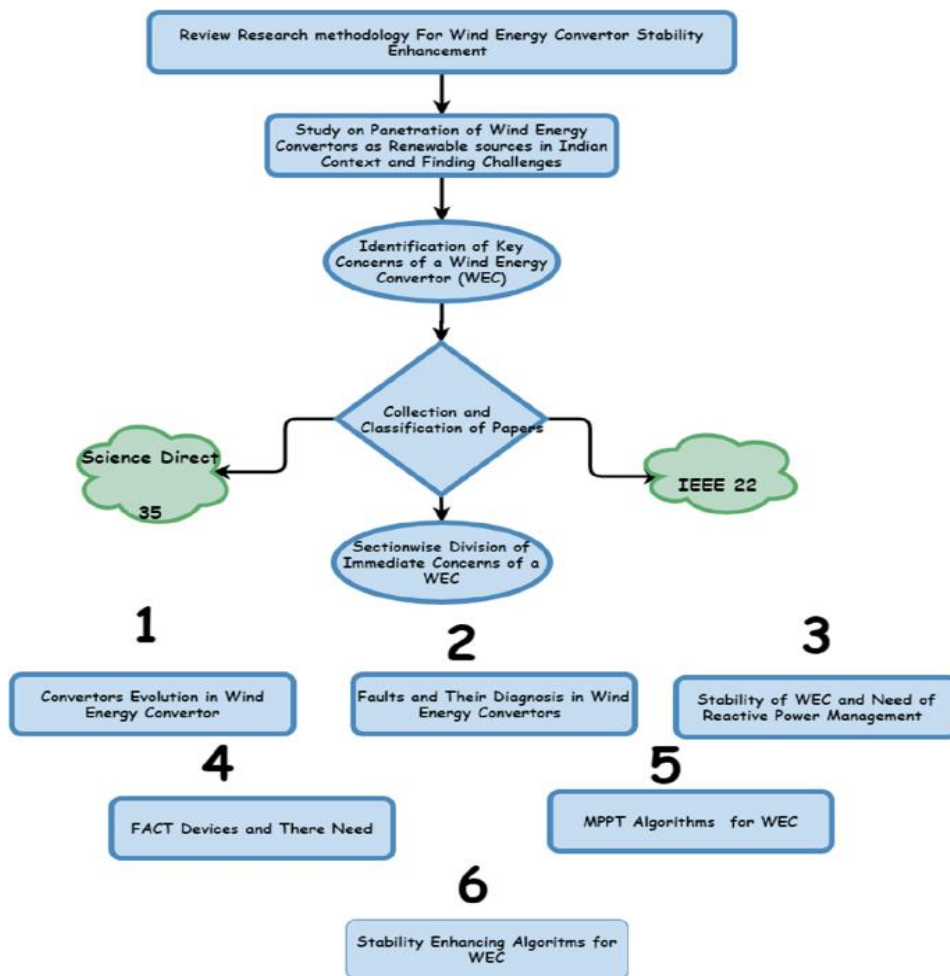

Figure 5: Outline for the Review Paper

Converters Evolution in Wind Turbine

Applications For dispersed source power interfaces, network couplers, energy quality devices, non-active power compensation, and power system power flow control, power electronic converters are required [6]. The storage of DC energy is typical in AC power converters. These are the weak points of a generator. Power system converters may occasionally be replaced by converters lacking DC energy storage. Without DC energy storage, AC-AC converters serve as examples of power system applications. AC-AC converters without DC-ESE are displayed. For DVRs that are AC-powered, use this adaptor. The AC-AC matrix and matrix-reactance chopper come first. Circuits for voltage regulators and power control do not alter frequency. A solid-state transformer was used initially [7]. Another topology in this group, power converters, only modify a portion of the energy. Transformers and AC-AC converters are combined in hybrid transformers [6, 7]. Frequency converters are AC-AC converters without DC-ESE. Gadget analysis. Compact AC-AC converters.

Power Electronics in the Wind Power Context

Quality standards are rising as TSOs view wind farms as another generation technology. WT technology uses power electronics (PE) components to generate a power quality-compliant electrical output. PE devices in wind blades serve this purpose, but not exclusively. PE maximizes power output in the wind turbine's control system.

Wind turbines need grid IDs. Grid codes govern wind power grid connectivity. Fault ride-through, active, frequency, voltage, and reactive power controllers are the main ones.

Systems for controlling wind turbines use power electronics. When the grid is unstable or the wind is strong enough to damage the turbine, they manage the aerodynamic system to produce the most electricity at any wind speed. They also limit output or stop generation in those situations.

Power converters are electronic devices that use semiconductors to convert electrical signals from one form or level to another. They are an important part of power electronics, which involves the control and conversion of electrical energy. Power converters can be found in various applications, such as wind turbine power converters and FACTS systems. Market research shows that the use of power electronics, especially power converters, is increasing.

Wind turbines with power converters now make up 85% of the market share, up from 44% in 2000. Manufacturers are introducing more wind turbines with full-power converters, and there have been no significant new models of older configurations in Western countries in the past 4 years. As grid code requirements become more stringent and demand for reliability and cost reduction increases, power electronics, including power converters, will become standard in all large wind turbines. Soon, older types of wind turbine configurations will no longer be installed.

Fault and Its Diagnosis in Wind Power Converter

Short-Circuit (SC) faults and Open-Circuit (OC) faults are two common errors in power semiconductor devices [8]. Power converters have a high current or voltage when a wind turbine starts or gusts. Heat dissipation performance decline and power semiconductor fatigue accumulation can damage devices over time. Corrosive gas, moisture, and dust in wind farms can cause power semiconductor devices to malfunction or fail catastrophically. SC faults [9] generate abnormal overcurrent that can damage the converter and other components. Stop the driver immediately.

OC faults take time to damage the system. It decreases converter efficiency. An OC fault offsets the currents in the faulty phase and the healthy phase, causing high harmonic distortion, oscillating generator torque, and falling grid power factor. However, the OC error may cause secondary component errors. OC faults can damage other switches. Converters need OC error FDs. Wind power converter has FD reliability and robustness issues. Wind power converter fault detectors need to be robust and reliable in the face of wind and load variations, as well as noise and bias in measured signals. Wind power converter FDs require constant accuracy. Wind power converter FDs methods require model-reality misfit resolution. This paper evaluates wind power converter FD techniques using more powerful performance indices in addition to robustness and reliability metrics. The following are the primary reasons why power semiconductor devices malfunction in wind power converters, as shown in Fig. 6 and Fig. 8.

Power semiconductor devices commonly fail short circuit and open circuit tests. Impact ionization, wrong gate signal, external failure, static/dynamic latch-up, high junction temperature, and impact ionization are other error processes. Bond-wise lift-off, solder layer breaking, and gate drive faults classify open circuit faults. These all have power semiconductor gadget flaws. Current-based converter FDs are favoured because they require no sensors and

are independent of converter parameters. The reference current error method and average current method define the excess using three-phase current impulses. It also contains the slope of the phase angle-based vector trajectory technique currently used. The third method, current vector shape, distorts output phase currents due to an open circuit fault [10]. Voltage-based methods assess switched bridge voltage and duration [11]. Error voltage-based method uses the average residue of pole voltages. Wind power converters use the following output voltage RMS method.

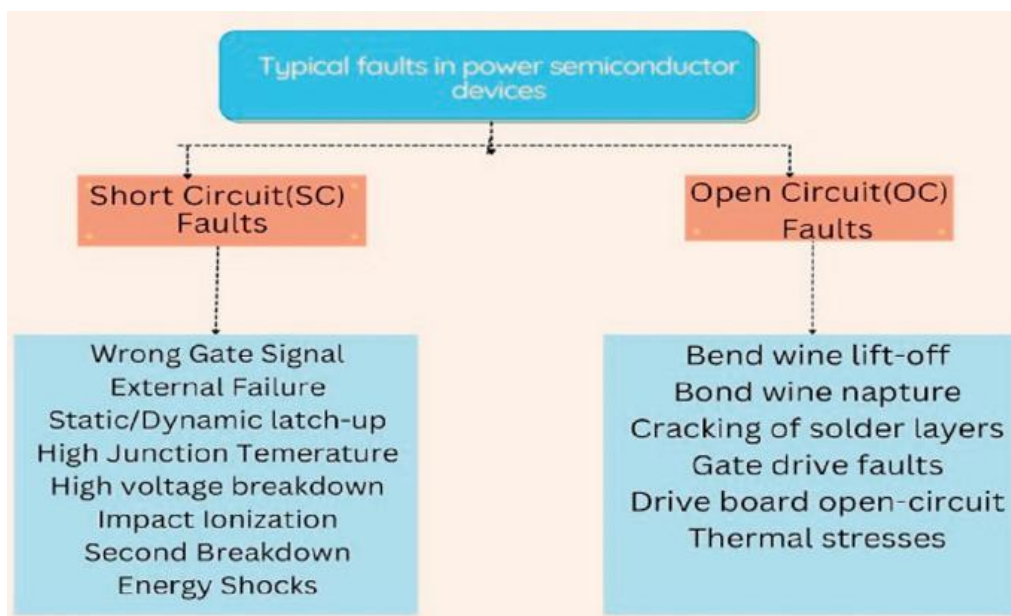

Figure 6: Typical Faults in Power Semiconductor Devices

Reactive Power and Voltage Stability in Wind Turbines

Most new renewable energy comes from wind. Due to the unpredictability of wind flow, large-scale wind farms may have an impact on the quality, safety, and stability of the electrical grid. Active power is based on the potential and design of wind turbine generators. Reactive power demand is calculated via conversion devices. Reactive power redistribution and voltage breakdown are caused by wind farms that are connected to the grid. Dynamic voltage stability is a problem for distributors [12]. Grid reactive power can be increased simply by using reactive power source devices and asset optimization. Including answers for stability, voltage control, reactive power, grid integration, unstable grid connections, off-grid wind power generation and integration, wind power penetration in the distribution grid, wind power uncertainty, flicker, and harmonics [13]. For different types of wind farms, reactive power regulation is required.

Power loss results from the long-distance reactive electricity transfer to wind turbines. Reactive power regulation for wind farms is necessary due to voltage fluctuation [11,12,13]. Due to network short circuit capacity and impedance, grid parameters have an impact on reactive power injection at various voltages. Reactive power adjustment is necessary for wind farms and their contributions to the grid since unadjusted reactive power impacts the hosting system and has lasting consequences. The following is a ranking of wind energy converter stability issues from 2012 to 2022. Table 1 summarizes the review of voltage stability of grid connection issues to maintain power quality along voltage stability.

Table 1: A Review of Voltage Stability and Grid-Connected Issues to Maintain Power Quality

Author	Year	Title	Findings
Zhou et al. [12]	2013	Connecting wind power plant with weak grid challenges and solutions	They discussed the issues in the integration of WEGs in the existing grid and highlighted the issue of Voltage stability
Singh et al. [13]	2015	Voltage stability of wind power by using the FACTS devices	They review several FACTS controllers for voltage stability analysis (VSA) of the power system
Badesa et al. [14]	2016	Impact of wind generation on dynamic voltage stability and influence of the point of interconnection	They highlight the analysis of PCC for remotely located wind energy system
Bayindir et al. [15]	2016	Effects of renewable energy sources on the power system	They use power factory software for simulating RE sources and comparative analysis between emergent changes to the bus voltage in the system before and after the interconnection of non-conventional energy sources is presented
Wu et al. [16]	2017	Influence on voltage stability of wind power connected to the grid	They used DFIG-based WT's model and performed simulation in the PSCAD tool for capacity-based Voltage stability analysis of the system
Rajalwal and Mishra et al. [17]	2018	Impact of DFIG on voltage stability of a network in smart grid: An analysis	They use the Modal analysis method for voltage stability analysis of the Wind-based DG system
Amirreza Gholizadeh et al. [18]	2018	A scenario-based voltage stability-constrained planning model for integration of large-scale wind farms	They employed the 118 IEEE Test bus system to conduct research on the Iranian grid for the interconnection of wind power. Additionally, describe the planning model with voltage stability constraints
Sree Latha et al. [19]	2018	Dynamic voltage stability enhancement of a wind farm connected to grid using facts- A comparison	They emphasized the use of FACTS for voltage stability enhancement they use SVC & Statcom for wind interconnected power system
Sheikh et al. [20]	2021	Voltage stability enhancement of grid-connected wind farm using hybrid D-STATCOM	Hybrid D-STATCOM improves voltage stability, reduces voltage deviations and active power loss
Nallagonda and Chandorkar [21]	2021	A novel voltage control strategy for a hybrid wind energy conversion system with STATCOM	STATCOM and hybrid voltage control strategy improves voltage stability, reduces THD and power loss
Li et al. [22]	2021	Voltage stability enhancement of wind farm based on hybrid SVC-STATCOM and optimal power flow	Hybrid SVC-STATCOM improves voltage stability and reduces power loss, OPF used for optimal operation
Guo et al. [23]	2021	Voltage stability enhancement of grid-connected wind farms using a hybrid UPFC	Hybrid UPFC improves voltage stability, reduces voltage deviations, and active power loss
Fahmy et al. [24]	2022	Voltage stability improvement of wind farm based on hybrid UPQC-STATCOM	Hybrid UPQC-STATCOM improves voltage stability, reduces voltage deviations, and active power loss
Dogramaci and Dursun [25]	2022	Power quality enhancement and voltage stability improvement of a wave energy converter system with a hybrid D-STATCOM	Hybrid D-STATCOM improves voltage

FACT Devices

Transmission line power handling, transient stability, system reliability, load management, and power flow control are all improved by solid-state flexible FACTS. The FACTS device family in Fig. 3 is briefly described below: (TSSC) thyristor-controlled series compensator Numbers TSSC (4), TSSR SVC (5), and SSSC (6). Seventh-grade Thyristor-Controlled Phase-Shifting Transformer (TCPST) with Static Synchronous Series Compensator UPFC The FACTS

devices and associated circuits are shown in the tables below. The most unpredictable renewable energy sources with widespread integration are wind energy conversion systems [26,27,28,29,30,31,32,33,34,35]. Numerous studies have looked at voltage stability with high penetrations in power grids. The most extensively researched WECS are DFIG, Squirrel-Cage, and PMSG. The SCIG-WECS employs grid-reactive power when it is included in a power system. Reactive power at the common connection is supported by a sizable stator line capacitor bank. Reactive power is used by DFIG-WECS to control bus terminal voltage. Compared to DFIG-WECS, SCIG-WECS reduces grid voltage reliability. Kamarposhti [30] compared the voltage stability of the SCIG-WECS and DFIG-WECS power systems. PV curves revealed paired maximum loading constraints of the WECS type. FACTS devices SVC and STATCOM for reactive power compensation were tested using an altered IEEE 14-bus test configuration. SVC was defeated in voltage help by STATCOM. Fahmy and Hamed [26] evaluated reactive power management during short circuit failure for STATCOM, SVC, and DFIG-WECS. SVC underperformed STATCOM. The top stability score is displayed in Fig. 7 which depicts FACT gadgets and their implementation with application. Table 2 shows the FACTS device. Figure 7 shows future research on FACTS devices for renewable energy integration and power system voltage stability.

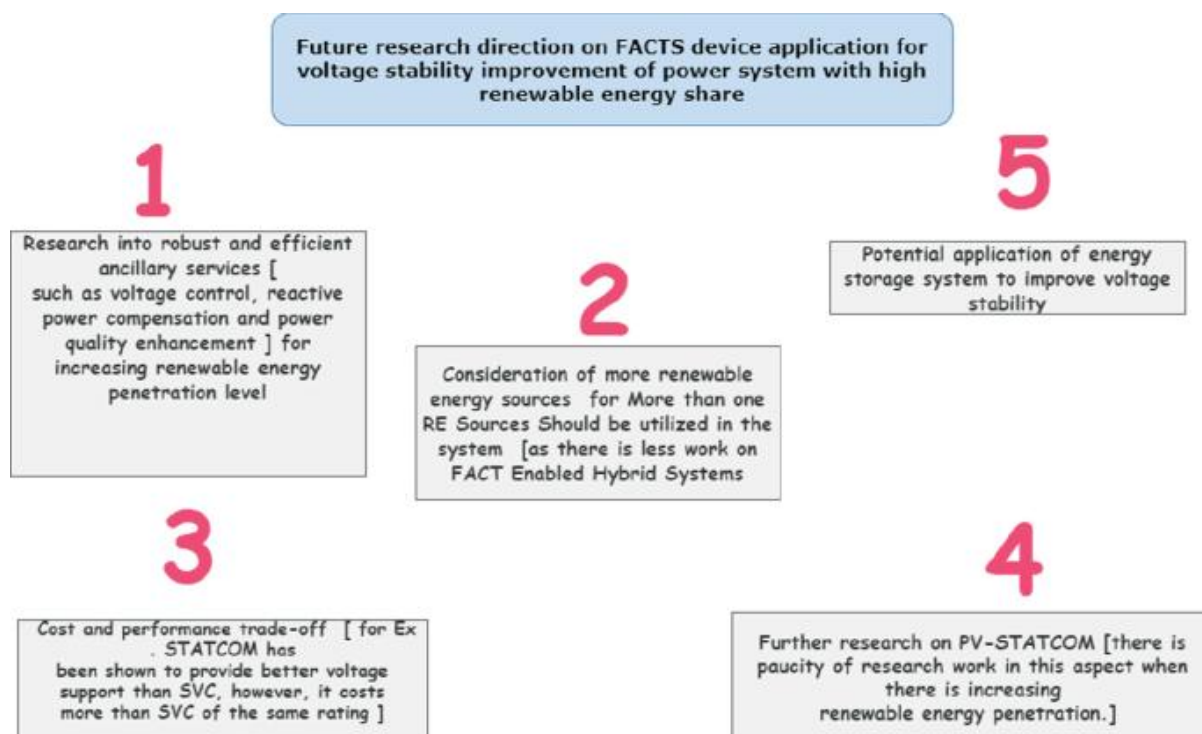
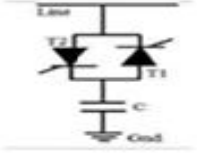

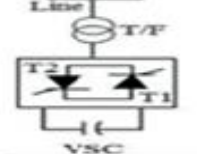

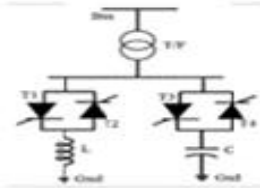

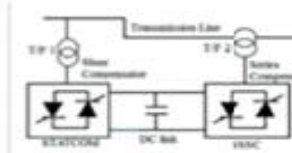

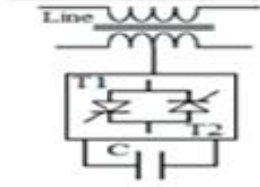



Figure 7: Further Technological Advancement Needed in FACT Devices for Integration with Renewable Hybrid System for Large Loads and Voltage Stability [26, 28, 29, 31, 32, 34]

Table 2: FACTS Device Application

Device Name	Equivalent Circuit	Pictorial View of Device	Application
TSC			<p>it provides fast response to the changes in the system parameters. And Faster control is achieved by the switching of thyristor operated devices.</p>
STATCOM			<p>it used for power quality control like flicker suppression and voltage sag elimination and to balance the phase voltages. In the case of renewable energy power generation STATCOM can be used for voltage stability and reactive power control.</p>
SVC			<p>Best for sudden short interruptions and improves transient stability of the system.</p>
UPFC			<p>Combination of SSSC and STATCOM</p>
SSSC			<p>Controls the Power factor of the system and enhance Power transfer capabilities.</p>

MPPT Algorithms Based Wind Turbines

PV systems and other RESs use MPPT algorithms like WECS. They estimate control factors like optimal power, voltage, and duty cycle, which are among the hardest. This paper will focus on WEC-based MPPT algorithm research. MPPT methods fall into two main categories: indirect and direct power controller represented as IPC and DPC, respectively [37, 38]. The DPC algorithms monitor the maximum power point by monitoring output electrical power, while the IPC algorithms boost output power by controlling mechanical power (P_m) using power-speed curve data. (MPP). Several MPPT methods use artificial intelligence controllers, which are rarely used in industry. During wind speed changes, MPPT algorithms like perturb and observe (P&O) and hill ascending search (HCS) are used to adjust control variables. The P&O algorithm, a sensor-free mathematical optimisation tool for MPP search, tracks control variables clearly. Many researchers recently chose the P&O MPPT algorithm study trend to enhance WECS-based captured wind power techniques for the following features:

No prior awareness of system parameters and memory needs; Low system complexity and cost; Sensor-less algorithm; Parameter insensitivity; Online updates. MPPT algorithms use IPC control methods like TSR, OT, and PSF [36, 37]. DPC algorithms—which use the P&O [39], incremental conductance (INC) [40], and optimum relation-based (ORB) MPPT algorithms—achieve the previously stated optimum relationship. This part summarises MPPT algorithms. Figure 8 represents the MPPT Algorithms Chart.

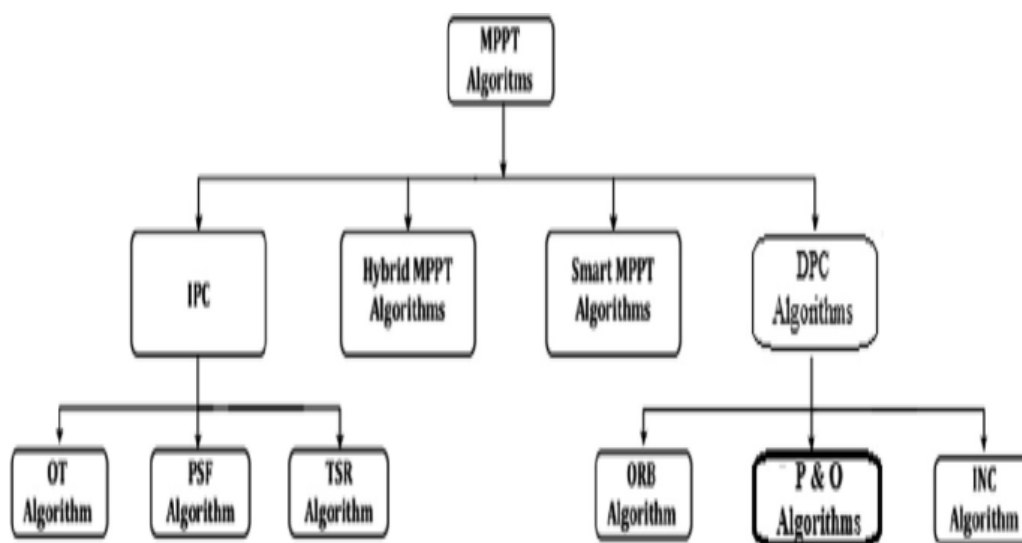
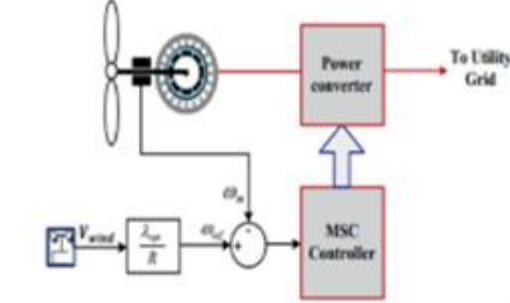
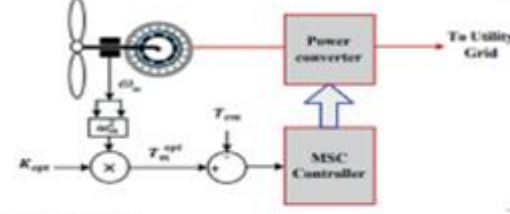
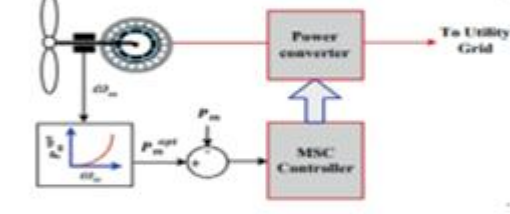
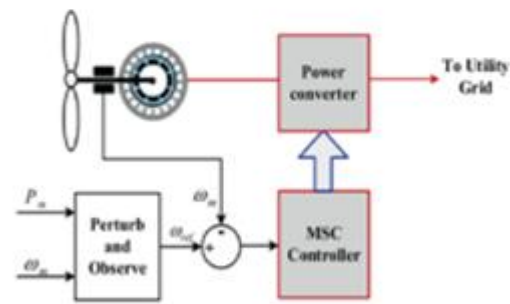
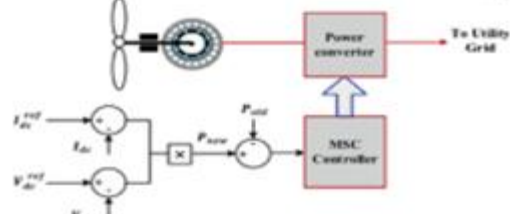

Figure 8: MPPT Algorithms Chart

Table 3: MPPT Algorithms in Wind Turbines

Name of Algorithm	Algorithm Implementation Procedure	Implementing Way
<p>TSR MPPT algorithm</p>	<p>(A) To offer the ideal rotor speed (ω_{ref}), the TSR algorithm calculates the best power extraction based on measured wind, rotor, and system parameters.</p> <p>(B) There are two basic techniques that compute wind speed or employ mechanical sensors: (i) With an accuracy of 5-10%, TSR algorithms based on mechanical sensors calculate the effective wind speed using a large number of anemometers within the swept zone of the WT. (ii) The tracking and energy harvesting of TSR are impacted by the accuracy of wind speed estimation (WSE).</p>	 <p><u>TSR Algorithm</u></p>
<p>OT MPPT algorithm</p>	<p>MPPT efficacy is determined by ideal WT. The OT algorithm requires experimental validation in order to guarantee simplicity, speed, and efficiency.</p>	 <p><u>OT Algorithm</u></p>
<p>PSF MPPT algorithm</p>	<p>The PSF is calculated using experimental power lookup tables or WT simulation tests. De-link change and wind speed are estimated using sensorless PSF approaches. This calculates effectiveness.</p>	 <p><u>PSF Algorithm</u></p>
<p>P&O MPPT algorithm</p>	<ul style="list-style-type: none"> The P&O algorithm changes rotor speed and de-link voltage to observe WECS effects. The classic P&O (CPO) MPPT algorithm greatly influences power and generator speed until the P-V curve slope is zero. The CPO algorithm does not need WT parameters or anemometers. CPO agitates control variables with a precise step-size and tracks goal function achievement until MPP place is obtained. 	 <p><u>P&O Algorithm</u></p>
<p>INC MPPT algorithm</p>	<p>The INC algorithm improves the effectiveness and reliability of WECS without the use of mechanical sensors or WT knowledge. The output power is controlled by keeping an eye on the de-link voltage (vdc) and current, as shown in the diagram.</p>	 <p><u>INC Algorithm</u></p>

The right MPPT method maximises wind power regardless of wind randomness. This paper describes grid-tied WECS setups for WTs and generator topologies. Several MPPT algorithms are examined and critically analysed to determine the best one for a given application. This part helps researchers choose WEC power-boosting methods. Table 3 offers step-by-step instructions for several wind generator MPPT algorithms.

Conclusion

Research on methods to improve renewable energy is expanding in developing and underdeveloped nations. In the past, many manufacturers of wind energy converters, including Suzlon Energy, Enercon India, and others, have put their wind energy converters into service in coastal regions of India and other locations based on the required wind density. Previous studies have shown that wind energy converters experience faults, disturbances, the need for reactive power, and blackouts and delays when their demand is reduced. Therefore, this article reviews and studies the problems and difficulties with existing machines. This study examined the possible growth of the Indian wind industry and developed a research hypothesis that provides a thorough analysis of the problems and difficulties associated with grid integration for wind turbines. This study examined the development of converters in wind turbines and the faults that have occurred in them in previous years. It also examined the requirement for reactive power in WEC and the function of the FACT device. The methods for tracking maximum power from WEC are reviewed and analysed in the final section. The role of algorithms is also studied, as they were helpful for tracking maximum power with improved power quality and stability. With the rise in electricity demand and the difficulty of producing clean, green electricity, there is a greater need for renewable energy sources. Only using solar during the day has encouraged people to look for better and more stable opportunities in the wind industry.

References

1. <https://economictimes.indiatimes.com/industry/energy/power/india-ranks-3rd-in-renewable-energy-country-attractive-index/articleshow/83771652.cms>. Accessed 4 April 2023
2. <https://energy.economictimes.indiatimes.com/news/renewable/indias-total-installed-wind-power-capacity-touches-40-89-gw-in-july-end/93463708>. Accessed 4 April 2023

3. <https://www.power-technology.com/projects/jaisalmer-wind-park-india/>. Accessed 4 April 2023
4. http://powermin.nic.in/sites/default/files/uploads/Notification_Interstate_Transmission_Charges_for_Renewable_Energy_Sources.pdf. Accessed 4 April 2023
5. “National Institute of Wind Energy”, Ministry of New and Renewable Energy, Government of India. <https://niwe.res.in/>. Accessed 4 April 2023
6. L. Meegahapola, D. Flynn, Impact on transient and frequency stability for a power system at very high wind penetration, Power and Energy Society General Meeting, pp. 1–8 (2010).
7. M. Edrah, K.L. Lo, O. Anaya-Lara, Impacts of high penetration of DFIG wind turbines on rotor angle stability of power systems. *IEEE Trans. Sustain. Energy* 6, 759–766 (2015).
8. A. Cichowski, P. Banach, W. Sleszynski, J. Nieznanski, Comprehensive distortion compensation of grid-connected inverter currents. In: *Proceedings of IECON 2014, Dallas*, pp. 1331–1336 (2014)
9. B. Lu, S. Sharma, A literature review of IGBT fault diagnostic and protection methods for power inverters. *IEEE Trans. Ind. Appl.* 45(5), 1770–1777 (2009)
10. J. Liang, K. Zhang, A.A. Durra, D. Zhou, A novel fault diagnostic method in power converters for wind power generation system. *Appl. Energy* 266(1), 114851 (2020)
11. Sarika D. Patil, Improvement of power quality considering voltage stability in grid connected system by FACTS devices. *Int. J. Electr. Electron. Eng.* 1(3), 41–19 (2012)
12. Y. Zhou, D.D. Nguyen, P.C. Kjær, S. Saylor, Connecting wind power plant with weak grid—Challenges and solutions, in *2013 IEEE Power & Energy Society General Meeting, Vancouver, BC*, pp. 1–7 (2013)
13. R. Praveen Kumar, C. Venkatesh Kumar, Wind turbine voltage stability using FACTS device. *Int. J. Emerg. Technol. Comput. Sci. Electron.* 8(1), 104–109 (2014)
14. J. Singh, N. Chand, Voltage stability of wind power by using the FACTS devices. *Chandigarh Univ. J. Undergrad. Res. Innov.* 1(1), 7–10 (2015)

15. L. Badesa, S. Fathima, M.T. Musavi, P. Villeneuve, Impact of wind generation on dynamic voltage stability and influence of the point of interconnection, in *2016 IEEE Green Technologies Conference (GreenTech)*, Kansas City, MO, pp. 84–89 (2016)
16. R. Bayindir, S. Demirbas, E. Irmak, U. Cetinkaya, A. Ova, M. Yesil, Effects of renewable energy sources on the power system, in *2016 IEEE International Power Electronics and Motion Control Conference (PEMC)*, Varna, pp. 388–393 (2016)
17. Z.D. Wu, P. Dong, Y.C. Chen, Influence on voltage stability of wind power connected to the grid, in *2017 7th International Conference on Power Electronics Systems and Applications - Smart Mobility, Power Transfer & Security (PESA)*, Hong Kong, pp. 1–5 (2017)
18. Z.H. Al-Tameemi, Abuuwaleda et al., Voltage stability enhancement based on DG units, *Electrical Engineering*, Springer
19. N.K. Rajalwal, P. Mishra, Impact of DFIG on voltage stability of a network in smart grid: an analysis, in *2018 Technologies for Smart-City Energy Security and Power (ICSESP)*, Bhubaneswar, pp. 1–9 (2018)
20. A. Gholizadeh, A. Rabiee, R. Fadaeinedjad, A scenario-based voltage stability constrained planning model for integration of large-scale wind farms. Elsevier, *Int. J. Electr. Power Energy Syst.* 105, 564–580 (2018)
21. S. L. K., V. K. M., Dynamic voltage stability enhancement of a wind farm connected to grid using facts—A comparison, in *2018 International Conference on Circuits and Systems in Digital Enterprise Technology (ICCSDET)*, Kottayam, India, pp.1–4 (2018)
22. S.A. Sheikh, A. Kumar, S. Jain, Voltage stability enhancement of grid-connected wind farm using hybrid D-STATCOM. *Electrical Engineering*, pp. 1–16 (2021)
23. V.K. Nallagonda, M.C. Chandorkar, A novel voltage control strategy for a hybrid wind energy conversion system with STATCOM. *Electric Power Compon. Syst.* 49(17), 1888–1901 (2021)

24. J. Li, L. Zhu, Y. Yang, J. He, Voltage stability enhancement of wind farm based on hybrid SVC-STATCOM and optimal power flow. *IEEE Trans. Sustain. Energy* 12(2), 862–872 (2021)
25. M. Guo, H. Jia, C. Wang, J. Wen, Voltage stability enhancement of grid-connected wind farms using a hybrid UPFC. *Int. J. Electr. Power Energy Syst.* 129, 107438 (2021)
26. M. Fahmy, M. Hamed, Voltage stability improvement of wind farm based on hybrid UPQC-STATCOM. *Electric Power Compon. Syst.* 50(1), 68–84 (2022)
27. E. Dogramaci, E. Dursun, Power quality enhancement and voltage stability improvement of a wave energy converter system with a hybrid D-STATCOM. *Int. J. Energy Res.* 46(5), 5497–5510 (2022)
28. P. Kundur et al., Definition and classification of power system stability IEEE/CIGRE joint task force on stability terms and definitions. *IEEE Trans. Power Syst.* 19(3), 1387–1401 (2004)
29. A.B. Almeida, E.V. V.d. Lorenci, R.C. Leme, A.C.Z.D. Souza, B.I.L. Lopes, K. Lo, Probabilistic voltage stability assessment considering renewable sources with the help of the PV and QV curves, *IET Renew. Power Gener.* 7(5), 521–530 (2013)
30. M.A. Kamarposhti, A comparative study of the implementation wind farms integration based on maximization of voltage stability and system loadability. *Trakia J. Sci.* 14(3), 294–304 (2016)
31. J. Liu, Y. Xu, Z.Y. Dong, K.P. Wong, Retirement-driven dynamic VAR planning for voltage stability enhancement of power systems with high-level wind power. *IEEE Trans. Power Syst.* 33(2), 2282–2291 (2018)
32. T. Tayyebifar, M. Shaker, M. Aghababaie, Performance comparison of STATCOM versus SVC to improve reactive power control in wind power based DFIG under short circuit fault, in *2014 Ninth International Conference on Ecological Vehicles and Renewable Energies (EVER)*, pp. 1–7 (2014)

33. J.N. da Costa, J.A. Passos Filho, R. Mota Henriques, Loading margin sensitivity analysis in systems with significant wind power generation penetration, *Electr. Power Syst. Res.* 175, 105900 (2019)
34. K.Z. Heetun, S.H.E. Abdel Aleem, A.F. Zobaa, Voltage stability analysis of gridconnected wind farms with FACTS: static and dynamic analysis, *Energy Pol. Res.* 3(1), 1–12 (2016)
35. A. Rabiee, S. Nikkhah, A. Soroudi, Information gap decision theory to deal with long-term wind energy planning considering voltage stability. *Energy* 147, 451–463 (2018)
36. M. Jadidbonab, M.J. Vahid-Pakdel, H. Seyedi, B. Mohammadi-ivatloo, Stochastic assessment and enhancement of voltage stability in multi carrier energy systems considering wind power. *Int. J. Electr. Power Energy Syst.* 106, 572–584 (2019)
37. H. Rezaie, M.H. Kazemi-Rahbar, enhancing voltage stability and LVRT capability of a wind-integrated power system using a fuzzy-based SVC. *Eng. Sci. Technol. Int. J.* 22(3), 827–839 (2019)
38. M. Darabian, A. Jalilvand, Improving power system stability in the presence of wind farms using STATCOM and predictive control strategy. *IET Renew. Power Gener.* 12(1), 98–111 (2018)
39. A. Rashad, S. Kamel, F. Jurado, Stability improvement of power systems connected with developed wind farms using SSSC controllers. *Ain Shams Eng. J.* (2017)
40. M.B. Wafaa, L. Dessaint, Approach to dynamic voltage stability analysis for DFIG wind parks integration. *IET Renew. Power Gener.* 12(2), 190–197 (2018)